

Professional Rework Station 2-in 1 & ESD Safe

Statement: The company reserves the right to improve & upgrade products, product specifications and design are subject to change without notice.

OPERATION INSTRUCTION

English



Made in China

Thank you for purchasing this product. Please read the manual carefully before operating and keep this manual for future reference.

SPECIFICATION

Main Unit Dimensions	L170xW150xH126mm ±5mm
Operating Temperature	0~40°C / 32~104°F
Hot Air Rework Station	
Air Delivery	Brushless fan with smooth air delivery
Output Volume	≤120L/min
Temperature Range	100~480°C/212~896°F
Display	LCD
Soldering Station	
Temperature Range	200~480°C/392~896°F
Display	LCD
Tip to Ground Resistance	<2 ohms

I. APPLICATIONS

1. This unit is great for desoldering and soldering applications on small components, such as SOIC, CHIP, QFP, PLCC, BGA, SMD packaging, and more. This unit is especially suited for desoldering operations on sockets in in-line packaging.
2. The unit's applications include heat shrinking, drying, paint removal, glue removal, defrosting, pre-heating, glue soldering, and more.

II. CONTROL PANEL

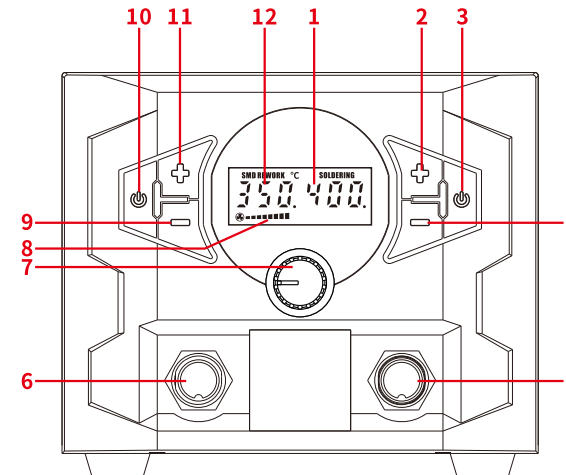

1. Temperature Display (Soldering Station)
2. Temperature Increase Button (Soldering Station)
3. Power Button (Soldering Station)
4. Temperature Decrease Button (Soldering Station)
5. Receptacle (Soldering Iron)
6. Receptacle (Hot Air Rework Station)
7. Air Volume Adjustment Knob / Function Knob
8. Air Volume Display (Simulated Value)
9. Temperature Decrease Button (Hot Air Rework Station)
10. Power Button (Hot Air)
11. Temperature Increase Button (Hot Air Rework Station)
12. Temperature Display (Hot Air Rework Station)

Note: There are two versions (A/B) of the station that supports different functions via the function knob.

Version A: °F/°C Unit Switch Function Knob ☒ 110V-127V~☒

Version B: Hot/Cold Air Mode Function Knob (220V-240V~)

Please refer to the voltage tag to determine the version of the station.

III. OPERATION

Hot Air Rework Station

1. Installation of the nozzle holder.
Install the nozzle holder onto the right-side of the main unit.
The screws MUST be fastened securely.
2. Installation and removal of the hot air gun nozzle.
(Caution: the nozzle should only be removed and installed when the nozzle is cooled.)
 - (1) Installation of the hot air gun nozzle. (2-1-1)
(the use of a larger diameter is recommended)
Place the hot air gun nozzle into the nozzle holder
→Align the hot air gun's steel with the nozzle, insert the hot air gun until the nozzle is securely installed onto the hot air gun.
 - (2) Removal of the hot air gun nozzle. (2-1-2)
Slot the hot air nozzle into the U-shaped opening → separate the hot air gun from the nozzle horizontally.

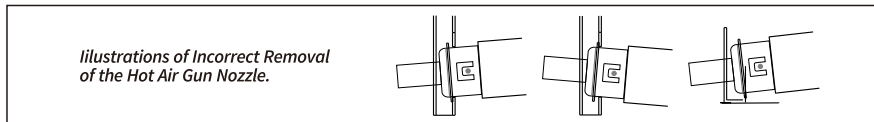
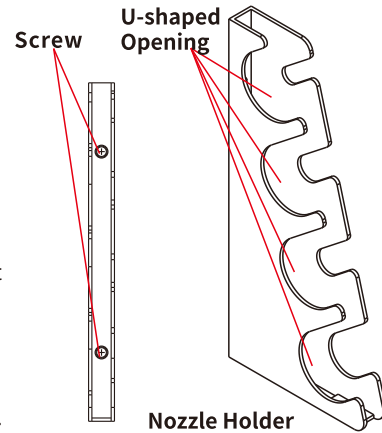

Caution: The hot air gun must be pulled up HORIZONTALLY to avoid damaging the hot air gun.

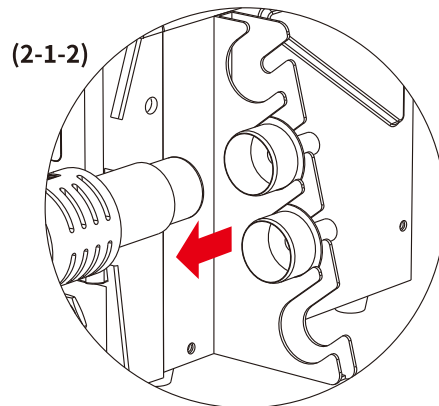
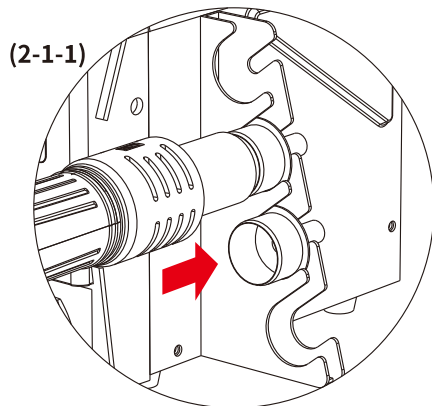

3. Set the rework station correctly. Install the hot air gun holder to the left side of the station and place the hot air gun onto the holder.
4. Install the required nozzle (Use of large-diameter nozzles is recommended) and connect the station's power cord to an electrical outlet.
5. Turn ON the power switch, and the temperature display shows "—" to indicate the hot air gun in standby mode. Set the desired temperature by using the increase and decrease buttons, and then pick up the hot air gun. The hot air gun will enter its standard operation status, and the hot air gun's operation indicator light (the dot located at the bottom-right corner of the temperature display) turns ON. The indicator stays ON when the hot air gun is heating up, blinks rapidly when the temperature is stabilized and turns OFF when the hot air gun is cooling. Adjust the air volume adjustment knob to set the appropriate air volume and begin operation once the temperature has stabilized. The operation indicator blinks rapidly when the temperature enters stabilization. At this point, the precision PID program tracks and compensates the hot air gun's actual temperature every millisecond. The hot air gun is now in the high-precision thermostatic state.



6. When the operation is complete, place the hot air gun back to the holder. Turn OFF the power button (hot air), and the operation indicator light of the hot air gun turns OFF. The hot air gun now enters cool air mode to cool the heating element. When the temperature drops below 100 °C/212°F, the hot air rework station's temperature display turns OFF. If the station is not in use for an extended period, turn OFF the station's master switch and DISCONNECT the station's power plug.

Soldering Station

1. Connect the soldering iron handle to the station and place the soldering iron into the iron holder.
2. Turn ON the master switch, then turn ON the soldering station's power button. The soldering station's heating element will begin heating normally, and the station's operation indicator light (the dot located at the bottom-right corner of the soldering station's display) turns ON. The indicator light stays ON when the soldering iron is heating, blinks rapidly when the temperature is stabilized, turns OFF when the soldering iron is cooling. Begin the operation when the soldering station's operation indicator light blinks rapidly to indicate temperature stabilization. CAUTION: Upon the first use of the soldering iron, set the temperature to 250°C/482°F. When the iron is just hot enough to melt solder, coat the soldering iron tip with a layer of solder (the use of rosin is recommended), then set the temperature to your desired value.



CAUTION: Upon the first use of the soldering iron, set the temperature to 250°C/482°F. When the iron is just hot enough to melt solder, coat the soldering iron tip with a layer of solder (the use of rosin-core solder is recommended), then set the temperature to your desired value.

- When the operation is complete, use a damp sponge or brass wool ball to clean the soldering iron tip. Tin the soldering iron tip with a new layer of solder again, then put the soldering iron back to the holder, and turn OFF the soldering station's power button. If the station is not in use for an extended period, DISCONNECT the power cord.

● Digital Temperature Calibration

Temperature discrepancies may occur due to the change in the environment's temperature or due to the replacement of the heating element, soldering tips and other components. You can correct the discrepancies with this function. The temperature calibration function can help improve work efficiency and extend the lifespan of the soldering iron.

- Once the hot air rework station (soldering station) reaches temperature stabilization, press and hold both the hot air rework station (soldering station)'s temperature increase and decrease buttons for approximately 2 seconds. The display shows "CAL" while alternating the display value with the set temperature.
- Press the hot air (soldering station) temperature increase or decrease button to enter the measured temperature value.
- Once done entering, press the hot air rework station (soldering station)'s temperature increase and decrease buttons at the same time to confirm entry. The system automatically calibrates the temperature and exits the calibration interface.

● °C/°F Display Setting

This function allows the station to comply with user preferences in different regions.

Version A: Press the function knob to select either the Fahrenheit or Celsius display mode.

Version B: Press the function button to select either the Fahrenheit or Celsius display mode or, press and hold the function button for approximately 2 seconds, then, press the function button 2 times. The display shows "C" or "F", and turn the air volume adjustment knob to select either the Fahrenheit or Celsius display mode. Once done selecting, stop operating for approximately 6 seconds, the system automatically saves the data and exits the setting interface.

● Hot / Cool Air Modes (Version B)

Once the hot air gun is started-up, press the function button, and the hot air gun's temperature begins cooling down. When the hot air temperature is cooled to below 70°C(158°F), the station will enter cool air mode. Press the function button again, the station will return to the normal hot air mode.

● Sleep Mode Count Down Timer Duration

This function extends the lifespan of the soldering iron, conserves energy, and protects the environment.

- Turn ON the soldering station's power button, then, press and hold the function button for approximately 2 seconds. The display shows value "SLP 010" to indicate that the countdown timer is set to 10 minutes.
- Turn the function knob to set the required countdown timer duration. The duration can be set to either 0 or 10 minutes. Set the duration value to 0 to turn OFF sleep mode.
- Once done setting, stop operating for approximately 6 seconds, the system saves the data and exits the setting interface.



To start up the station from sleep mode:

- Shake the soldering iron a few times.
- Press any button on the soldering station.
- Turn OFF, then turn ON the station.

● Buzzer Prompts

- Turn ON the soldering station's power button, then, press and hold the function knob for approximately 2 seconds. Release the function knob, then, press the function knob 1 time, and the display shows "BEL ON" or "BEL OFF".
- Turn the air volume adjustment knob to turn ON or turn OFF the buzzer prompter. Once done setting, stop operating for approximately 6 seconds, the system saves the data and exits the setting interface.

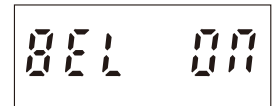

● Hot Air Gun Fail-safe Protection (Hot Air Rework Station)

When the hot air gun stops putting out air abnormally during an operation, the system will automatically cut off the power to the heating element. This is to prevent the burn damages on the handle due to heat accumulation from not putting air out. This function further improves the safety of the product.

● Auto Shutdown

When the soldering station enters sleep mode, its CPU will begin counting down. If the soldering station is not wakened after 30 minutes, the soldering station will automatically shut off. Please restart the soldering station by turning OFF the power switch and then turn ON.

Note: The auto shutdown function is ONLY activated when the sleep mode is turned ON.

● IV. MAINTENANCE & PRECAUTIONS

● Hot Air Rework Station

1. Keep the air outlet clear and free of blockages at all times.
2. The installation of the hot air nozzles MUST be carried out ONLY when the steel pipe and nozzle have cooled. Install the nozzle correctly, DO NOT install the nozzle with brute force, pull the edge of the nozzle with tweezers, or over-tighten the screws.
3. Select the appropriate nozzle based on your operation requirement (temperatures may vary when you use nozzles in different diameters). When using nozzles smaller than the stock nozzles, you MUST use the maximum air volume with a relatively lower temperature setting. Complete this operation in the shortest duration possible to prevent damaging the hot air gun.
4. Keep a minimum distance of 2mm between the subject and the hot air gun's air outlet.
5. DO NOT allow the hot air to come in direct contact with facial parts, and beware of the danger of burn injuries. Upon the first use, the hot air gun may emit white fumes, and the white fume will dissipate in a short while.

NOTE:

The station's hot air gun and soldering iron handles use high-strength stainless steel tubes. The station goes through 4 times or more testing, inspection, and calibration procedures before rolling off the assembly line. The steel tube may exhibit light bronze color as a result of our quality control efforts. It is normal to have a slightly bronzed steel tube when you using a brand-new station; Rest assured for regular usage.

● Soldering Station

1. If a layer of oxidization forms on the surface of the soldering iron tip, a misconception can be created that the tip cannot heat up properly to melt the solder and do the tinning. However, the actual temperatures of both the heating element and tip are high. In such an instance, please do not increase the temperature value further but use a metal wool ball to remove the oxidization following the steps below:

A. Set the temperature to 300°C (572°F).

B. Once the temperature stabilizes, gently rub the soldering iron tip inside the metal wool ball.

C. When the oxidization is partially removed, continue applying solder onto the soldering iron tip while rubbing it until the tip is completely coated with solder. If the tip is too severely oxidized beyond cleaning, replace it with a new one.







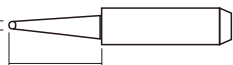

2. DO NOT use metal files to remove the oxidization on the soldering iron tip. If the soldering iron tip deforms or rusts, replace the soldering iron tip with a new tip.
3. DO NOT apply excessive force on the soldering iron tip when soldering. This will not only not improve the heat transfer but damage the soldering iron tip instead.
4. When placing the soldering iron back in the holder to idle after a high-temperature operation, adjust the temperature to 250°C (482°F) or below for idling. Failure to do so, and leaving the soldering iron tip to idle on a high-temperature setting will cause the accelerated aging of the heating element and shorten the lifespan of the heating element and soldering iron tip.
5. After every operation, clean the soldering iron tip, then tin the tip with a new layer of solder to prevent oxidization.

● V. TROUBLESHOOTING

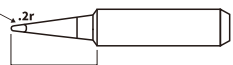
1. S-E - This is an indication that the station's sensor module is faulty. You need to replace the heating element (the heating element and the sensor modules). Or it may be that the soldering iron has not been connected (Turn OFF the power, connect the soldering iron, then turn ON the station again.)
2. F-1/F-2 - This is an indication that the hot air gun is in the zero-air protection mode. The hot air gun and the hot air gun's power circuitry require inspection in this instance.
3. When replacing the heating element, take note of the original connecting order and colors of the wires which MUST NOT be connected incorrectly.
4. SLP - This is an indication of sleep mode being active.

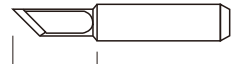
Tip style (specifications and sizes)

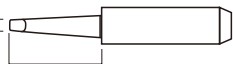
902 Series Tip Out Diam ϕ 6.5mm

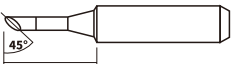
902-B	 ϕ 3.2mm	 17mm
0°C		
902-I	 ϕ 3.2mm	 17mm
-10°C/-18°F		
902-K	 ϕ 5.0mm	 15mm
30°C/54°F		
902-3.2D	 ϕ 3.2mm	 17mm
0°C		
902-3C	 ϕ 3.0mm	 17mm
0°C		