

- ⑥ Disconnect the wires connected to the heating element and remove the heating element.
- ⑦ Install the new heating element
- ⑧ Connect the wires as per the original (factory) wiring order.
- ⑨ Assemble the desoldering gun in the reverse order of the disassembly, and calibrate the temperature.

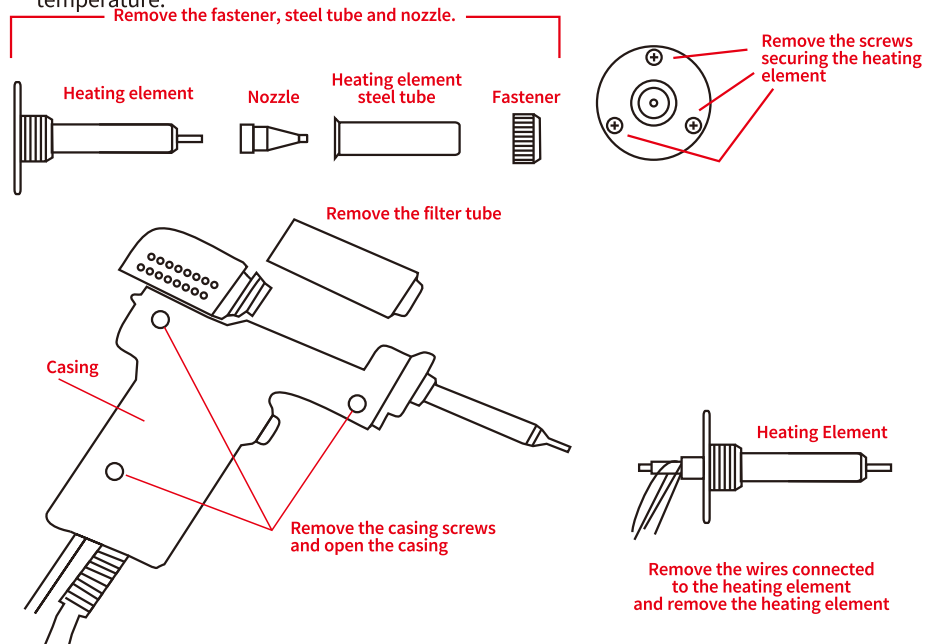

Desoldering Station 2-in-1 & ESD Safe

OPERATION INSTRUCTION

English

V. TROUBLESHOOTING GUIDE

1. S-E – This is an indication that the station's sensor module is faulty. You need to replace the heating element (the heating element and the sensor modules). Or, the soldering iron is not connected (Turn OFF the station, connect the soldering iron and turn ON the station).
2. SLP – This is an indication that the desoldering station is in sleep mode.



Made in China

Thank you for purchasing this product. Please read the manual carefully before operating and keep this manual for future reference.

Statement: The company reserves the right to improve & upgrade products, product specifications and design are subject to change without notice.

SPECIFICATION

Control unit dimensions	L234*W202*H134mm ±5mm
Operating ambient temperature	0~40°C/32°F~104°F
Desoldering gun temp. range	380°C~480°C/716°F~896°F
Soldering iron temp. range	200°C~480°C/392°F~896°F
Display	LED
Nozzle to ground resistance/ Tip to ground resistance	<2 Ohms
Vacuum Pressure	0.05MPa

I. APPLICATIONS

This unit is suitable for specialty desoldering applications on a broad-range of through-hole and other components. The station is especially great for desoldering operations on through-hole components with multiple pins or leads. (E.g., Transformer, LCD screen, LED, IC chips, In-Line pins and more)

II. CONTROL PANEL GUIDE

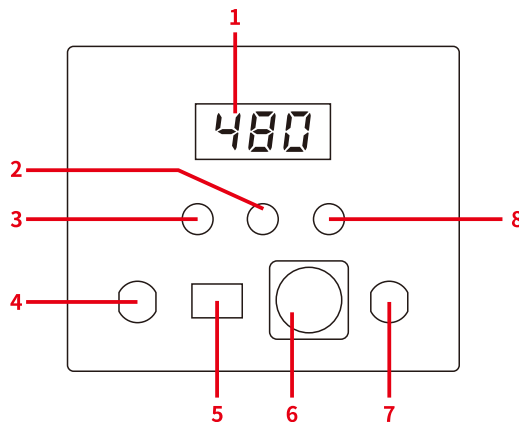

1. Temperature Display (Desoldering Station / Soldering Station)
2. Function Button
3. Temperature Decrease Button (Desoldering Station / Soldering Station)
4. Receptacle (Soldering Iron)
5. Power Switch (Desoldering Station / Soldering Station)
Note: The desoldering station and soldering station's power switch to CANNOT be turned ON simultaneously.
6. Receptacle (Suction Pump)
7. Receptacle (Desoldering Gun)
8. Temperature Increase Button (Desoldering Station/ Soldering Station)

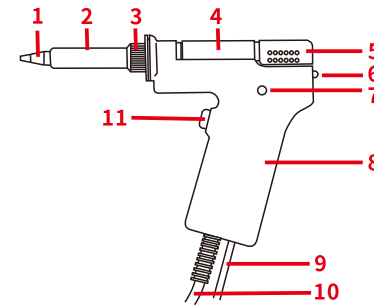

1. Nozzle (Consumable)
2. Steel Tube
3. Fastener
4. Filter (The filter spring inside is consumable)
5. Tube Release
6. Release Button
7. Indicator
8. Casing
9. Vacuum Tube
10. Cord
11. Desoldering Trigger

III. OPERATION

Desoldering Station

"Pht" - This is an indication that the desoldering station is pre-heating. The vacuum pump will not be activated when this code is active.

1. Connect the desoldering gun to the desoldering station.
2. Connect the desoldering station's power cord to an electrical outlet.
3. Push the power switch to the ON sign on the RIGHT-side, and the desoldering station's heating element will begin heating.

CAUTION: When using the desoldering nozzle for the first time, coat the nozzle with a layer of solder (Use of rosin core solder is recommended) when the nozzle is just hot enough to melt solder. This is to prevent the oxidization of the desoldering nozzle.

4. Press the temperature increase or decrease button to set the desired temperature. After switching ON the desoldering station's power switch, the station requires time to pre-heat to the operating temperature before desoldering operations.
5. When the operation is complete, put the desoldering gun back to the holder and turn OFF the power switch. DISCONNECT the power cord when the station is not in use for an extended period.

To desolder: cover the component's pin/lead with the desoldering nozzle, and melt the solder on the pin/lead. Then, press on the desoldering trigger to extract the solder completely.

Soldering Station

1. Connect the soldering iron correctly, and put the soldering iron in the holder.
2. Connect the station's power cord to an electrical outlet.
3. Push the power switch to the ON sign to the LEFT-side, and the soldering station's heating element will begin heating. The soldering station's operation indicator light (the dot located at the bottom-right corner of the soldering station display) will turn ON. The operation indicator light will stay constantly ON when station heating up, blink rapidly when the temperature is stabilized, and be turned OFF when station cooling. Begin your operation once the soldering station's indicator is blinking rapidly to indicate temperature stabilization.



Indicator for Real-Time Temperature Tracking & Temperature Compensation

CAUTION: Upon the first use of the soldering iron, set the temperature to 250°C/482°F. When the iron is just hot enough to melt solder, coat the soldering iron tip with a layer of solder (the use of rosin core solder is recommended), then set the temperature to your desired temperature.

- When the operation is complete, use a damp sponge or metal wool ball to clean the soldering iron tip. Tin the soldering iron tip with a new layer of solder, then put the soldering iron back to the holder and turn OFF the power switch. The station's power switch MUST be turned OFF, and the power plug MUST be DISCONNECTED when the station is not in use for an extended period.

CAUTION:

- Melt the solder completely before pressing the desoldering trigger.
- If the PCB's hole has residual / left-over solder, resolder, then repeat the desoldering procedure.
- If the component's pin/lead is stuck on the side of the hole, and the solder is unable to be extracted completely. Apply more solder to resolder, and then use the nozzle to melt the solder joint, move back-and-forth gently to get the component's pin/lead moving. When the pin/lead is no longer in contact with the hole, press down on the desoldering trigger to extract the solder completely.
- Press down on the desoldering trigger, if the indicator exhibit a full red, or more than 1/2 red in color, you need to clean the nozzle, heating element, and filter tube. If the indicator is blue or slightly red, no cleaning is required.
- The desoldering nozzles come in different sizes. The larger nozzles are suitable for desoldering components with large pins/leads, and the smaller nozzles are suitable for those with small pins/leads. Select the nozzles in appropriate sizes for your work.

Fahrenheit/Celsius Temperature Display

This function allows the station to comply with different user preferences for users in different regions.

Turn ON the desoldering station's power switch, OR the soldering station's power switch. Press the function button to select the Fahrenheit or Celsius Display mode. Once done selecting, stop operating for approximately 2 seconds, the system automatically saves the setting – Setting complete.

Sleep Mode

This function extends the service life of the heating element, conserves energy, and protects the environment.

- Turn ON the power switch for the soldering station, and press the function button for approximately 2 seconds. The display will then show the value "SLP".
- Press the temperature increase or decrease button to set the desired sleep mode timer. You can select timer value of 5, 10, 15, 20, or 30 minutes. Set the timer value to OFF to turn OFF sleep mode.
- Once done setting, stop operating for approximately 5 seconds, the system will save the data and exit the setting interface automatically – Sleep mode setting complete.

NOTE: With the soldering station ON, the sleep timer value will be set for the soldering station. With the desoldering station ON, the sleep timer value will be set for the desoldering station.

To wake the station from sleep mode:

- Pick up the soldering iron and shake lightly to start-up from sleep mode. Or press the desoldering trigger to start-up the desoldering station from sleep mode.
- Press any button.
- Turn OFF, then turn ON the power switch.

Buzzer Configuration

- Turn ON either the desoldering station's or the soldering station's power switch, and then press and hold the function button for approximately 2 seconds. The display will show "SLP"
- Press the function button again, and then the display will show "BL"
- Press the temperature increase button to turn ON the buzzer, or press the temperature decrease button to turn OFF the buzzer.
- Once done setting, stop operating for approximately 5 seconds, the system will save the data and exit the setting interface automatically – Setting complete.

Digital Temperature Calibration

Temperature discrepancies may occur due to the change in the environment's temperature or due to the replacement of the heating element and other components. You can correct the discrepancies with this function. The temperature calibration function can improve work efficiency and prolong the lifespan of the heating element.

- Turn ON either the desoldering station's or the soldering station's power switch. After the temperature has stabilized, press and hold both the temperature increase and decrease buttons for approximately 2 seconds. The display will show 3 additional digit dots while showing the temperature.
- Press the temperature increase or decrease button to enter the measured temperature value.
- Press and hold both the temperature increase and decrease buttons for approximately 2 seconds to confirm the entry. The system will automatically calibrate, save the temperature value, and exit the setting interface – Temperature calibration complete. Repeat the calibration procedure should minor discrepancies occur.

IV. MAINTENANCE & PRECAUTIONS

Soldering Station

1. If a layer of oxidization forms on the surface of the soldering iron tip, a misconception can be created that the tip cannot heat up properly to melt the solder and do the tinning. However, the actual temperatures of both the heating element and tip are high. In such an instance, please do not increase the temperature value confusedly but use a metal wool ball to remove the oxidization following the steps below:
 - A. Set the temperature to 300°C (572°F).
 - B. Once the temperature stabilizes, gently rub the soldering iron tip inside the metal wool ball.
 - C. When the oxidization is partially removed, continue applying solder onto the soldering iron tip while rubbing it until the tip is completely coated with solder. If the tip is too severely oxidized beyond cleaning, replace it with a new one.

2. DO NOT use metal files to remove the oxidization on the soldering iron tip. If the soldering iron tip deforms or rusts, replace the soldering iron tip with a new tip.
3. DO NOT apply excessive force on the soldering iron tip when soldering. Doing this will NOT IMPROVE the heat transfer but damage the soldering iron tip instead.
4. When placing the soldering iron back in the holder to idle after a high-temperature operation, adjust the temperature to 250°C (482°F) or below for idling. Failure to do so, and leaving the soldering iron tip to idle on a high-temperature setting will cause the accelerated aging of the heating element and shorten the lifespan of the heating element and soldering iron tip.
5. After every operation, clean the soldering iron tip, then tin the tip with a new layer of solder to prevent oxidization.

● Desoldering Station

1. The cleaning and maintenance procedures of the desoldering nozzle are identical to that of the soldering iron tip.
2. Cleaning methods of the nozzle, heating element, and filter tube

A. Nozzle Cleaning

- *Plug the power plug into the power socket, and turn ON the power switch. Then set the temperature to 450°C/842 °F.
- *Once the temperature has stabilized, select the appropriate cleaning pin to clean the nozzle.



B. Heating Element Cleaning

- *Once the heating element has cooled, remove the fastener, steel tube, and nozzle.
- *Turn ON the power switch, and set the temperature to 450°C/842 °F. Once the temperature has stabilized, use an appropriate cleaning pin to clean the inner hole of the heating element.

*The power MUST be turned OFF after cleaning

CAUTION:

The solder in the heating element's inner hole must ONLY be cleaned when completely melted. If the cleaning pin cannot be put through the heating element's inner hole, change into a new heating element. When installing, tighten the fastener properly, or the nozzle temperature will be relatively low.



B. Filter Tube Cleaning

*Turn OFF the power switch, and wait for the filter tube to cool before removing the tube as instructed by the graph.

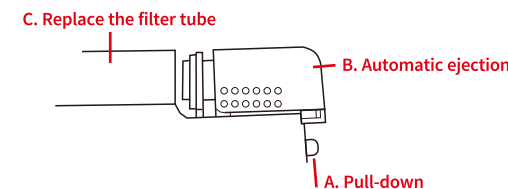

*Disassemble the filter tube as per the illustration in the below graph, and then remove the spring filter. Clean the solder off the spring filter.

CAUTION: The filter tube is extremely HOT, beware of burn injuries when cleaning.

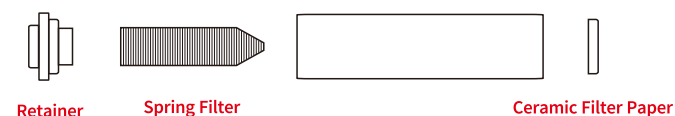

Replace the filter tube if any of the following conditions occur:

- *Unable to remove the solder from the spring filter, or the filter has collected more than 2/3 of solder of its capacity – Replace the spring filter
- *The retainer has hardened and cracked – Replace the retainer
- *The ceramic filter paper is hardened due to the over-accumulation of solder and flux – Replace the ceramic filter paper

3. Heating Element Replacement

- ① DISCONNECT the power cord, and wait for the heating element to cool.
- ② Remove the fastener, steel tube and nozzle.
- ③ Remove the locking screw securing the heating element.
- ④ Remove the filter tube.
- ⑤ Remove the casing screw and open the casing.